

Fish Processing Machine

MS18ST

for Fish Block & Frozen Meat

CUT·MAN

series④



One side-Table
Slide Type

One side & Both sides - Table Slide Type

Specification of the table surface can be chosen, depending on the material to be cut

High Speed Rotation

High efficiency and fine cutting surface, thanks to the increase of rotation

Power UP !

Lighten the all-round operator's work load, providing motors (1.5kw - 2.2kw)

SUS304

The frame, made of more durable stainless steel SUS 304, warrants 10 years' operation.

MS18ST

for Fish Block & Frozen Meat

One side-Table Slide Type

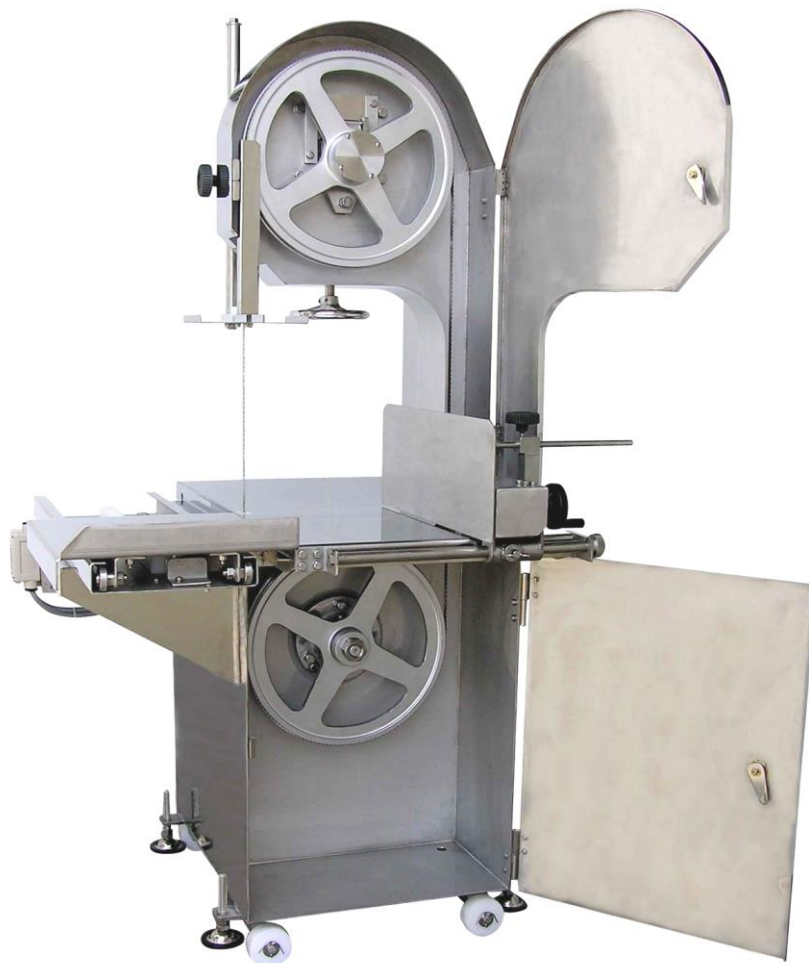

Fine cutting surface

Fine cutting surface, thanks to high speed rotation
Special saw blade promising higher yield rate

Flame SUS304

The frame, made of more durable stainless steel SUS 304, warrants 10 years' operation.

Easy Cleaning

All stainless steel body (SUS 304) with clean image and rust preventive & washable characteristics enable to clean all corners of the machine quickly.

Stainless Steel Tire (Wheel)

Use of stainless cast steel tire prevent derailment of saw blade due to the rust corrosion, and enable easier water washing.



Machine size

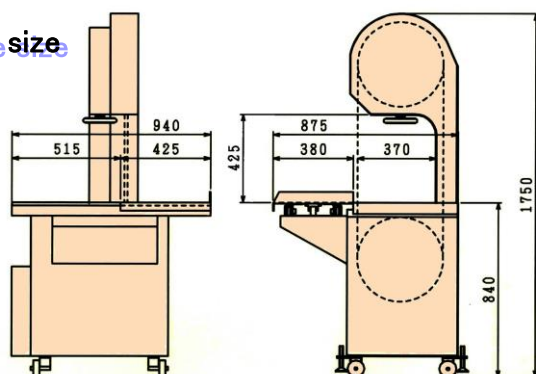

Specification

Max. sawing height	350H
Area (table)	1230x1200
Dimension (Machine)	1230x1200x2048H
Weight	440kg
Motor	1.5kw~2.2kw
Power Supply	3 Phase 200V 50/60Hz