

Fish Processing Machine

MS18-SS

CUT-MAN
series⑥

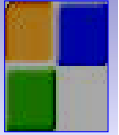

Band saw with auto-divider

For center cutting of Salmon, Sierra, Bream,

Anyone can operate in a minute.

You can use it on the day you purchase without subtle adjustment, just by slide into sending belt which with gearbox.

Excellent center deduction framework.

By using MKE original center deduction framework, it divides the fish into two even curved fish. It doesn't require round or dress.

It is hygienic and strong durability.

We use SUS304 for frame. It is rust-proof, non-corrosive and has high durability. We warranty for 10 years.

Beautiful section

The thin saw blade (0.5t) promises reducing of waste, beautiful section and high yielding.

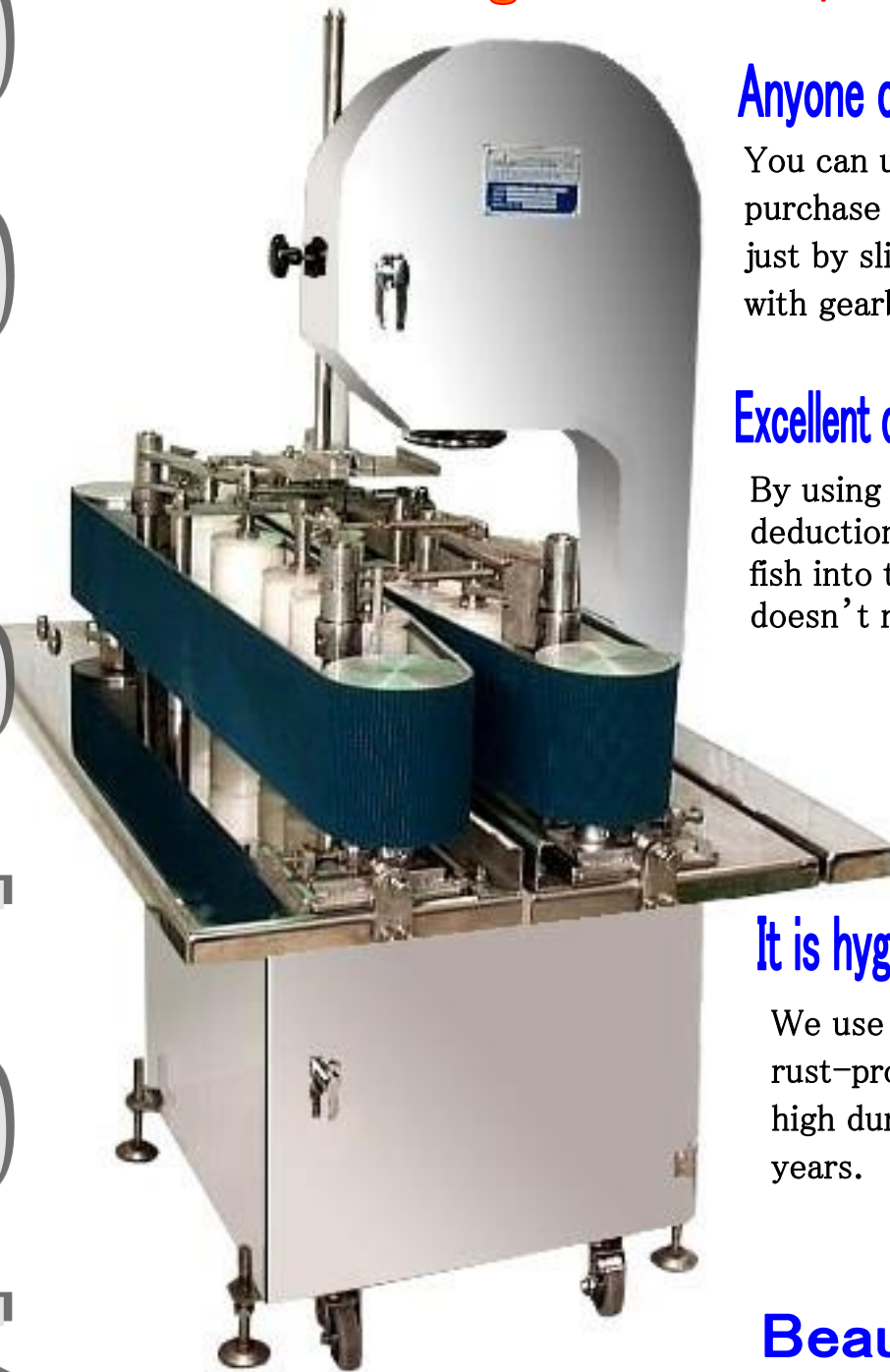

Band saw with auto-divider

Cutting



Bream



Salmon



Sierra

Whole cutting of bream.

Only head(skull) cutting also possible.

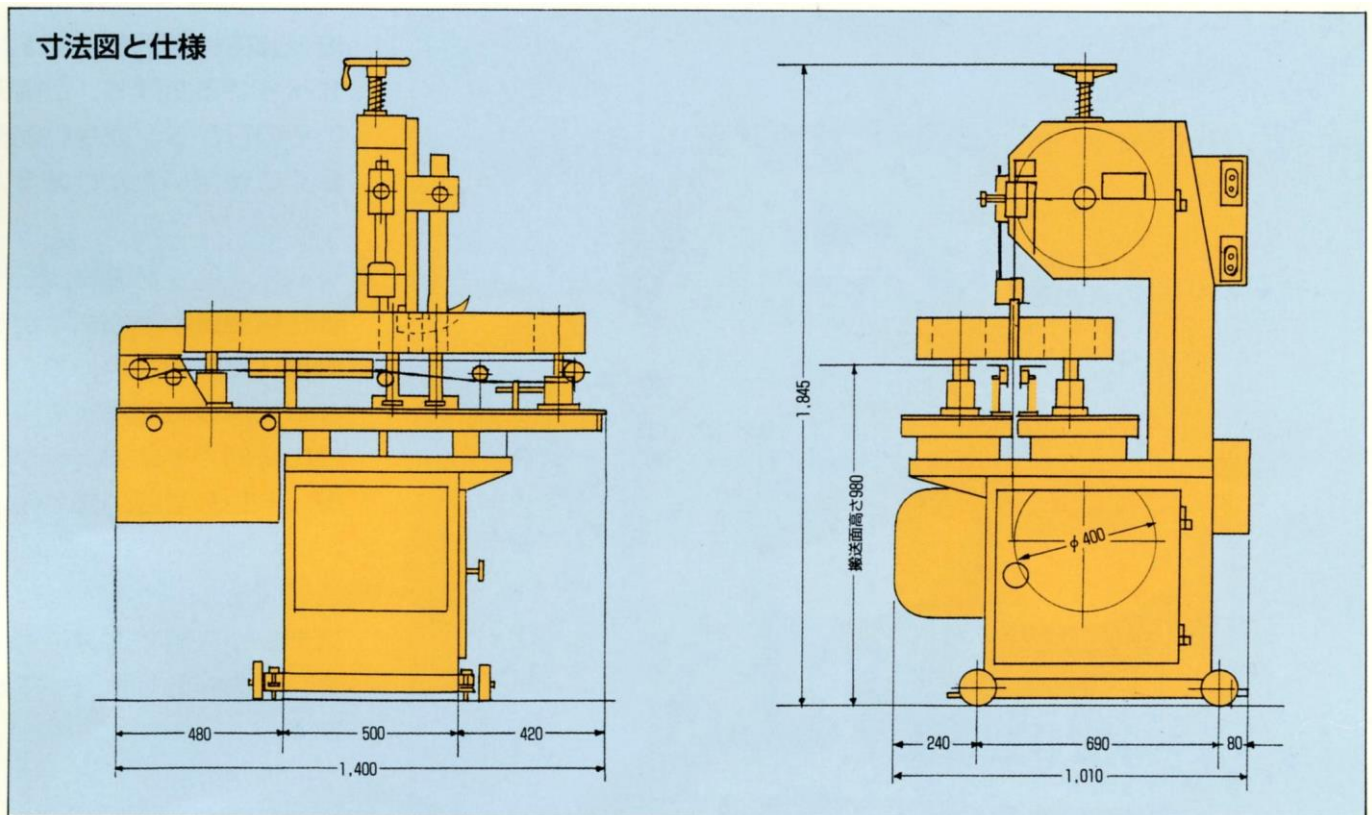

Machine specifications

Maximum cutting height	270mm	All over weight	600kg
Cutting thickness	20~100mm	Saw blade dimension	Thickness0.5×width19×length3150mm
Cutting sending speed	5~18m/min	Saw blade driving motor	1.5kw×4p
Machine dimension	Width1010×Depth1400 Height1845mm	Motor for sending	0.4kw×4p
Working ability	Frozen salmon 4~5t/day	Power source	Three-phase circuit AC 50/60 AC 200V~440V



MK Engineering

MKENGINEERING CO., LTD.

1060 ISHIZU, YAIZU-SHI,

SHIZUOKAKEN, 425-0041, JAPAN

TEL 81-54-625-8360 FAX 81-54-625-8361