

MKE

CUT-MAN
Series 9



CHC-10 *Processing Machine*

Automatic Crab Leg Cutter

Preliminary processing for shucked crab leg and crab portion

Making fine notch on the both sides (right/left) of shell

Keeping always constant notching depth 2.0mm - 3.0mm

No adjustment required

Simple operation by everybody

Washable (made of stainless steel)



No adjustment required !

Easier operation reputed

MK ENGINEERING CO.,LTD

1060 ISHIZU YAIZUSHI SHIZUOKAKEN 425-0041,JAPAN

TEL 81-54-625-8360 FAX 81-54-625-8361

Automatic Crab Leg Cutter

CHC-10

Preliminary processing for shucked crab leg and crab portion

Making fine notch on the both sides (right/left) of shell
Keeping always constant notching depth 2.0mm - 3.0mm
No adjustment required
Simple operation by everybody
Washable (made of stainless steel)

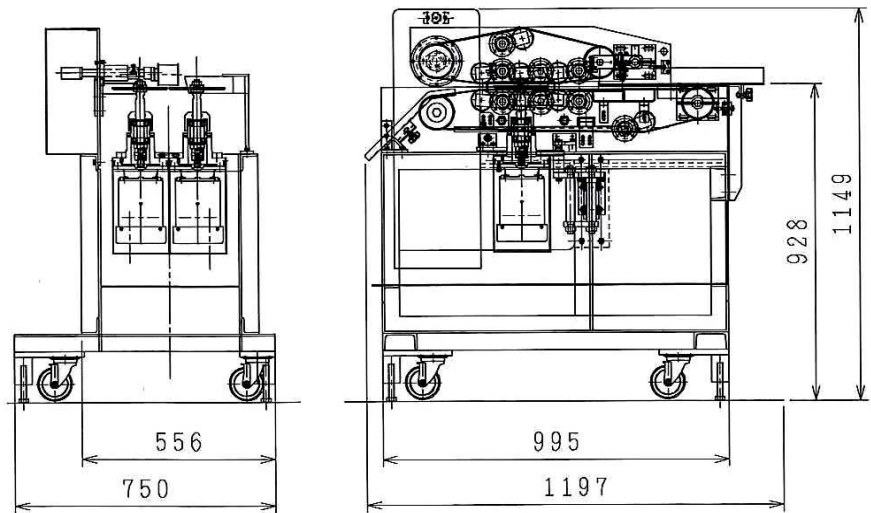

Processing Materials	: Crab legs & Crab parent claw
Max. cutting size	: 50mm (W) × 50mm (H)
Min. cutting size	: 6mm (W) × 8mm (H)
Capacity	: Snow crab 120kg/h
Notching depth	: 2.0 mm/3.0 mm
Power Supply	: 200V AC, 3 phase, 50/60Hz
Cutter	: 160mm (outer dia.) x 20mm (inner dia.) x 1.6mm (thickness) x 72 (tee)
Disks pushing down cutter	: 156mm x (outer dia.), 154mm (outer dia.). 1 set of each 4 disks
Conveyer Belt	: 51 mm (W) x 1240 mm (L), 51mm (W) x 1805mm (L), 1 set
Cutter Motor	: Closed Fan Motor 0.4kw, 4p, 2 sets
Belt Motor	: Geared Motor 0.2kw × 4P
Dimension	: 1288 (W) × 727 (L) × 1287 (H)
Weight	: 300kg

MK ENGINEERING CO.,LTD
1060 ISHIZU YAIZUSHI SHIZUOKAKEN 425-0041,JAPAN
TEL 81-54-625-8360 FAX 81-54-625-8361