

Fish Processing Machinery

"Compact & Friendly"

TK-305

T-Type Cutter, Exclusive Grinding Machine

Easier grinding work

Highly hygienic and durable body made of stainless steel

State of the art 「CUT-MAN Series」 developed by inovating approach

CUT-MAN
series 21

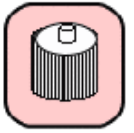

NEEDS

Market Needs

Increasing the operating efficiency is the most effective key for contributing to more profitability in fishery processing industries.

ANSWER

MKE's answer

Economical and capable machine, keeping easier operation and high quality processing, is required. Then, ...



MKE MK Engineering

Easily grinded

Once T-Type Cutter is set on the slide cramp, everybody can easily it by moving it, right and left.



Precise blade angle

The angle of the blade's top can be precisely set referring to the scale on the angle adjusting shaft.

High Power; AC 100V, 550W

1.5 times of output power (550 W) more than traditional grinding machine, in spite of the use of familiar power supply at home.

Fish Processing Machine "Compact & Friendly" TK-305



Shiny grinded surface

uniform and speedy grinding, thanks to specially big size of whet stone (outer dia. 305 mm)



Compact Design

More flexibility for the location to set the machine by providing 10L tank with flow control cock on the machine. (No need of water supply source near the machine)

Exclusive Grinding Machine for T-Type Cutter (1st application in this field)

This Exclusive Grinding Machine for T-Type Cutter can extremely increase the efficiency of grinding the T-Type Cutter

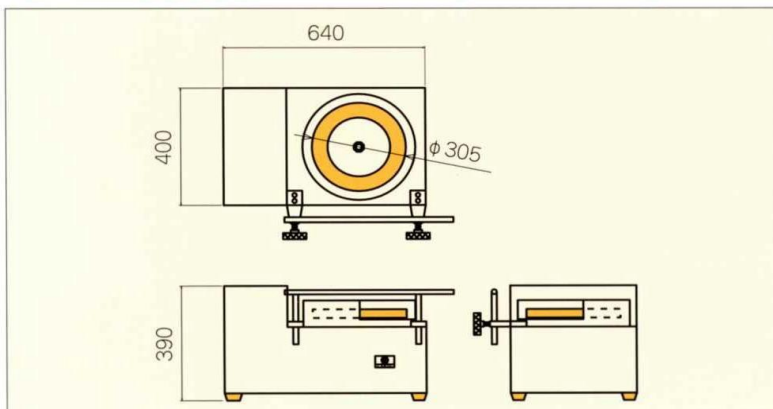

Specification

Dimension (table)	● 400 mm × 640 mm × 390 mm
Weight	● 50 kg
Whet stone Dimension	● Outside Dia. 305 mm × Inside Dia. 140 mm x Thickness 30 mm # 120
RPM of whet stone	● 480/580 rpm (50/60Hz)
Motor Output	● Condenser Motor 550w
Current	● 9.5/8.0A(50/60Hz)
Power Supply	● AC 100V, 1 Phase

MHE MK Engineering

MK ENGINEERING CO., LTD.
〒425-0041 1060 Ishizu,
Yaizu City Shizuoka Pref., Japan
TEL 81-54-625-8360 FAX 81-54-625-8361
<http://www.mk-e.co.jp>

Sales Agent