

MK ENGINEERING CO.,LTD

Fish Processing Machinery

series 16

Washing/Defrosting/Sterilizing Conveyer machine for tuna **MKS-300**



- Enable to sterilize, defrost, and wash tuna by powerful water jet generated through special nozzle
- Continuous feeding can shorten the working time

● with automatic feed water



● Powerful pump specialized to extremely high pressure

■ Specification

(unit : mm)

Container size	400W×600L×100H
Speed	V=3~15m/min (Continuous variable speed control by inverter)
Capacity	240 pieces /h
Power Supply(conveyer)	0.4kw 3 Phase 200V
Power Supply (High Pressure Pump)	3.7kw 3 Phase 200V×2

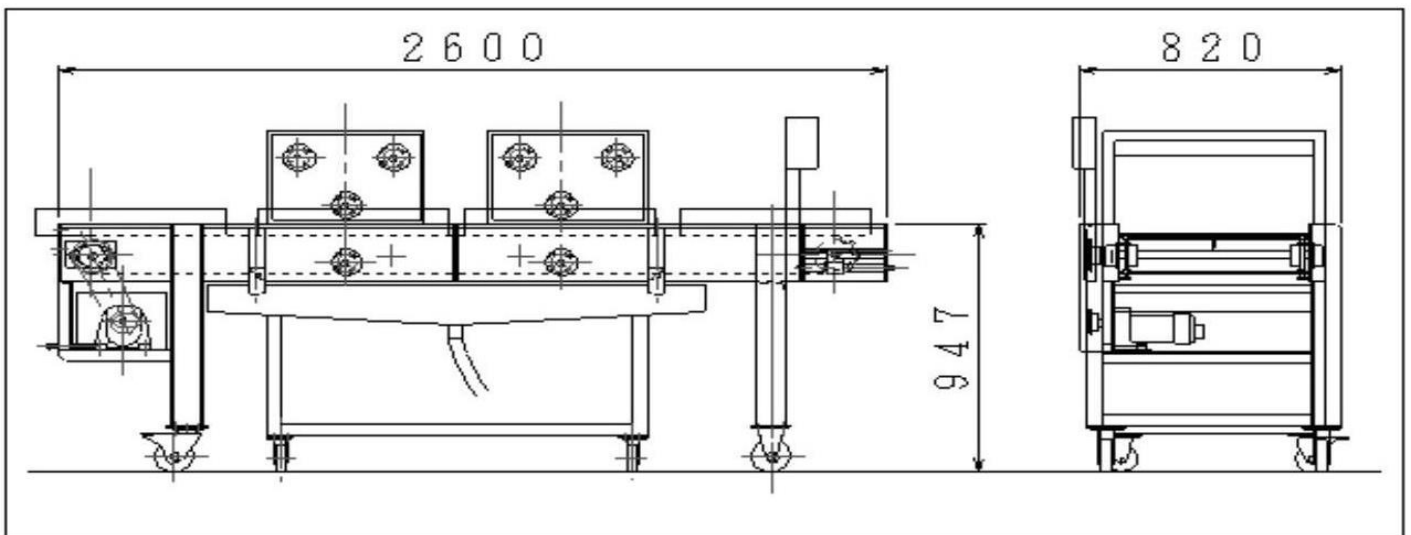

MHE *MK Engineering*

MK ENGINEERING CO., LTD.
〒425-0041 1060 Ishizu,
Yaizu City Shizuoka Pref., Japan
TEL 81-54-625-8360 FAX 81-54-625-8361
<http://www.mk-e.co.jp>

Sales Agent