

MS750

Fish Processing Machine

CUT-MAN

series ①

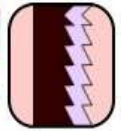

Big-size band saw for fresh frozen fish

Exclusive for four pieces cutting of frozen bonito and tuna

High Speed Rotation

It achieves the increasing processing efficiency and the beautiful section by increasing

Power Up

It equip the motor which goes 3.7kw to 5.5kw. It is allround player starting bonito up to tuna. It reduces the task of workers.

SUS304

We use a stainless steel frame of SUS304 which has excellent durability. With 10 years warranty.

Gutter. Adhere

You can choose a style of table surface depends upon the stuff you cut.



The processing efficiency greatly increases by this one machine.

MKENGINEERING CO., LTD.
1060 ISHIZU, YAIZU-SHI,
SHIZUOKAKEN, 425-0041, JAPAN
TEL 054-625-8360 FAX 054-625-8361



株式会社 エム・ケー・エンジニアリング

〒425-0041 静岡県焼津市石津1060
TEL 054-625-8360 FAX 054-625-8361

MS-750

Big-size band saw for fresh frozen fish

Saw blade tension light



We can decide the position of saw blade tension by lighting. By making identical tension, we can reduce a bearing or task over the saw blade and we can make efficient work.

Stainless steel tire



We equip this stainless steel tire. It solves the problem of running off of saw blade by the rust corrosion. It is easy to wash by water.

SUS304 frame

We use SUS304 for frame. It is strong in rust and corrosion, and has a high durability. With 10 years warranty.

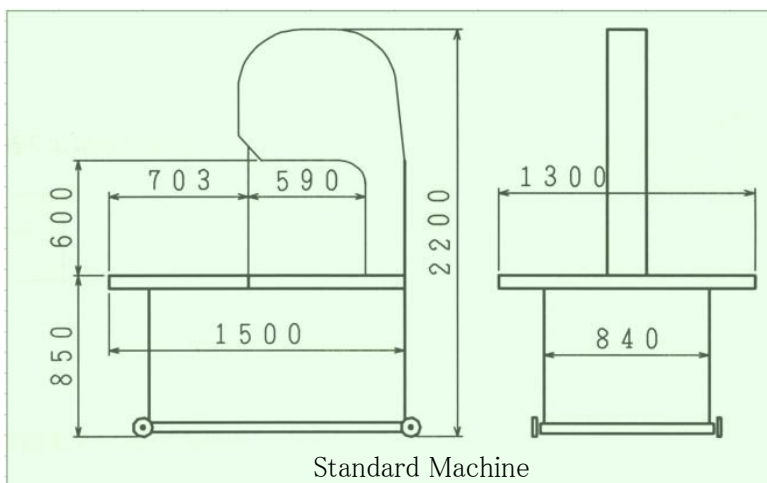

Standard Machine Specifications

Maximum pull cutting height	600H
Machine dimensions	1500Wx1300Dx2200H
All over weight	730kg
Motor	3.7kw
Power source	Three-phase circuit Hz 50/60 AC 200V~440v

Specifications of machine for tuna

Maximum pull cutting height	700H
Table dimensio	1500Wx1300Dx2300H
All over weight	750kg
Motor	5.5kw
Power source	Three-phase circuit Hz 50/60 AC 200V~440v

MKENGINEERING CO., LTD.

1060 ISHIZU, YAIZU-SHI,

SHIZUOKAKEN, 425-0041, JAPAN

TEL 054-625-8360 FAX 054-625-8361

